

UNIMAC CAST IRON VALVES

Cast Iron check Valve

DESIGN STANDARD IS : 5312. PART - I & PART - II. BS : 5153, BS : 1868.

SIZE RANGE 40 MM TO 1600 MM. FOR SWING TYPE, SINGLE & MULTI DOOR.
300 MM TO 2000 MM. FOR TILING DISC SWING TYPE.

TYPE OF DISC SWING CHECK, LIFT CHECK, TILTING DISC, DUAL PALTE.

PRESSURE RATING PN 0.05 TO PN 1.6 MPa, PN 4 TO PN 16 BAR.

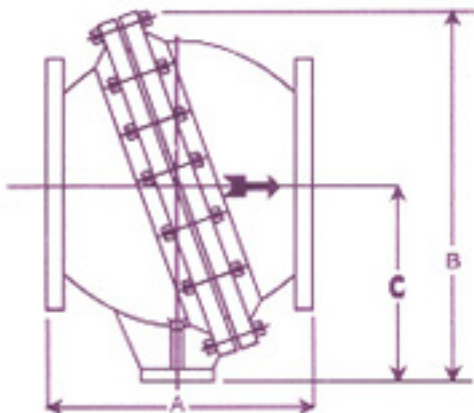
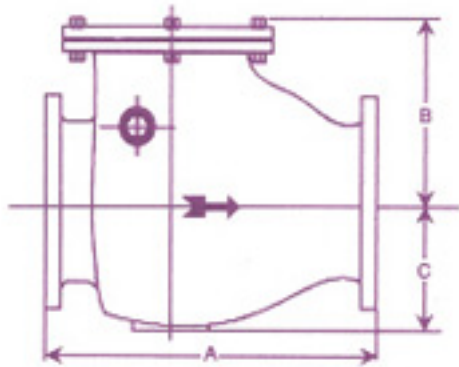
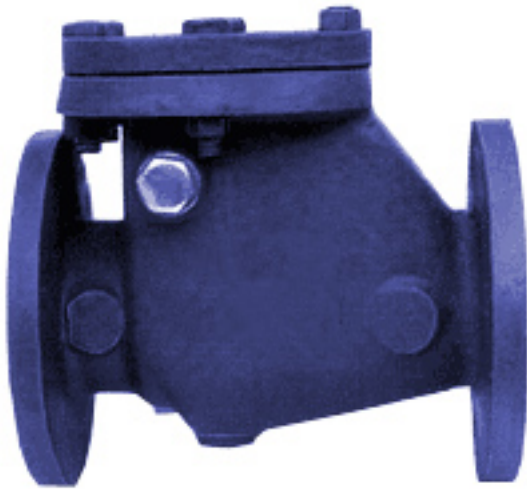

VALVE SIZE	A	B	C	APPX. WT. IN KG.
40	201	130	60	25
50	201	140	75	29
65	241	150	90	35
80	261	180	130	46
100	301	200	130	58
125	351	215	140	80
150	401	275	200	115
200	501	310	220	165
250	601	350	240	215
300	701	450	310	350
350	801	510	340	520
400	901	520	350	680
450	1001	580	420	900
500	1101	640	510	1100
600	1301	700	600	1600
500	816	1150	600	1500
600	915	1333	685	2100
700	1001	1446	750	2260
750	1046	1446	750	2500
800	1119	1634	850	2600
900	1251	1570	915	3500
1000	1251	1730	915	4100
1100	1397	2069	1080	5200
1200	1501	2250	1175	6400
1300	1651	2480	1340	7500
1400	1851	2800	1500	8200
1500	2081	3100	1700	9500
1600	2251	3500	1900	11000

All dimension are in mm

Note : Due to constant up gradation, dimensions are subject to change by the manufacturer.